

Lifting  
your  
world.



# CARROS ABIERTOS

Para grúas de proceso  
y grandes capacidades

**GH**  
CRANES & COMPONENTS

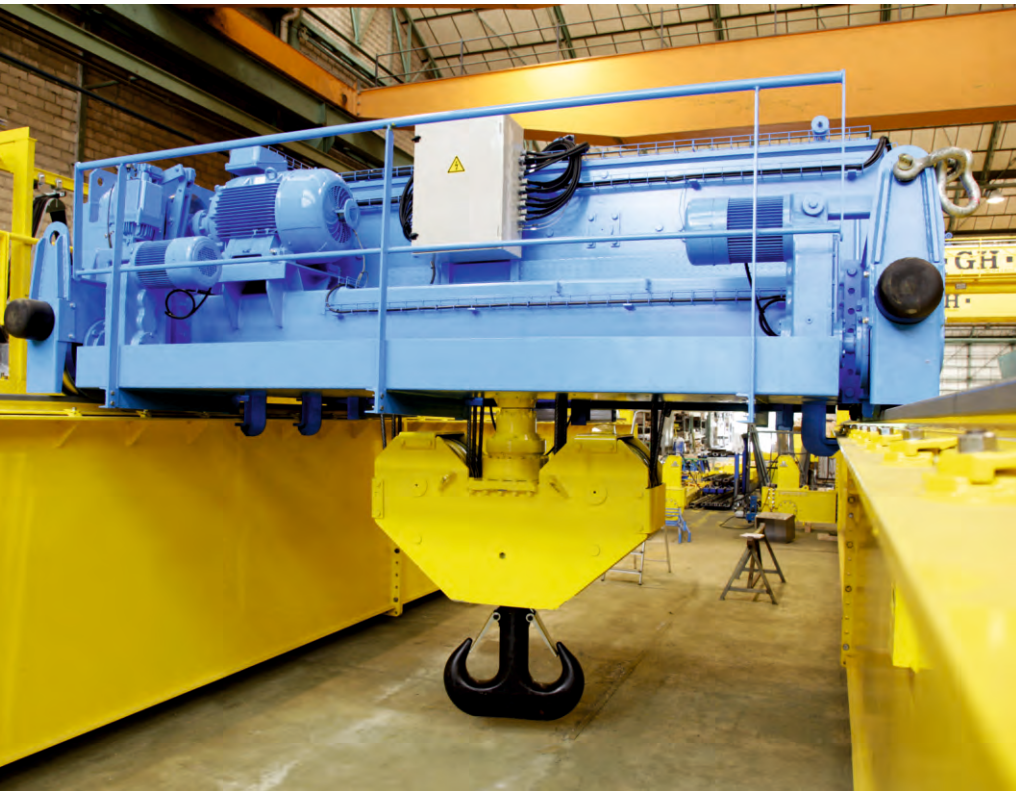

Estos tipos de carros se fabrican bajo demanda para atender unas necesidades, sobre todo de grúas de proceso, con características especiales, bien sean de capacidad, de seguridad o con velocidades u otros requerimientos particulares.

Cuentan con diseños modulares que utilizan subconjuntos independientes para facilitar el acceso a los componentes para mantenimiento, servicio, calibración e inspección.

Se desarrollan como estándar en una amplia gama de selección, desde 6,3t a 400t



ACOPLAMIENTOS ELÁSTICOS



FÁCIL ACCESO



TIRO VERTICAL



DETECTOR DE CABLE FLOJO



## ¿Por qué Carro Abierto?

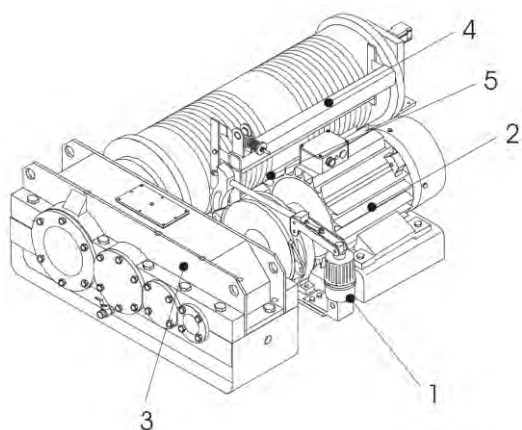

- 1.- Freno
- 2.- Motor
- 3.- Reductor
- 4.- Anticabalgamiento
- 5.- Tambor

### Ventajas del carro abierto:

- De manera general, un carro abierto permite mayor capacidad de elevación y/o mayores velocidades de elevación y/o grupos FEM mas altos, es decir realizan trabajos más severos.
- Posibilidad de trabajar con motores de 3.000, 1.500, 1.000 y 750 rpm. Mayor dimensionamiento del motor.
- Utilización de motores comerciales, pudiendo adecuarse al estándar del cliente. 1 motor, en lugar de aplicaciones con polipasto que necesitan 2 motores para la misma capacidad de elevación y por tanto doblan la probabilidad de fallo del equipo.
- El ataque motor reductor y reductor - tambor están realizados mediante acoplamientos flexibles intermedios, absorbiendo las inexactitudes de montaje y las deformaciones por fricción durante la elevación de la carga.
- Ejecución en tiro vertical, sin desplazamiento lateral del gancho durante el movimiento de elevación.
- Mayor accesibilidad para mantenimiento de los diferentes componentes.
- El freno es totalmente exterior, mejorando su accesibilidad y mantenimiento.
- Anticabalgamiento y detector de cable flojo: El anticabalgamiento está formado por un soporte y un mecanismo con resortes unidos con tornillos, cuyo objetivo es evitar que se salga el cable de las ranuras del tambor.

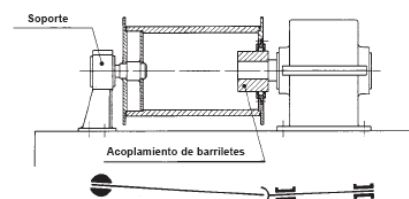

**Figura 1**

Ejemplo de carro con tambor simple y acoplamiento barrilete.

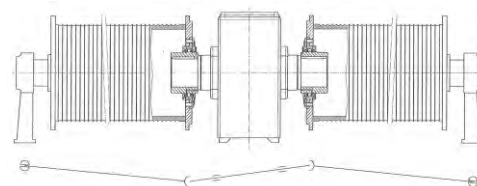

**Figura 2**

Ejemplo de carro de doble tambor con acoplamientos en el tambor.

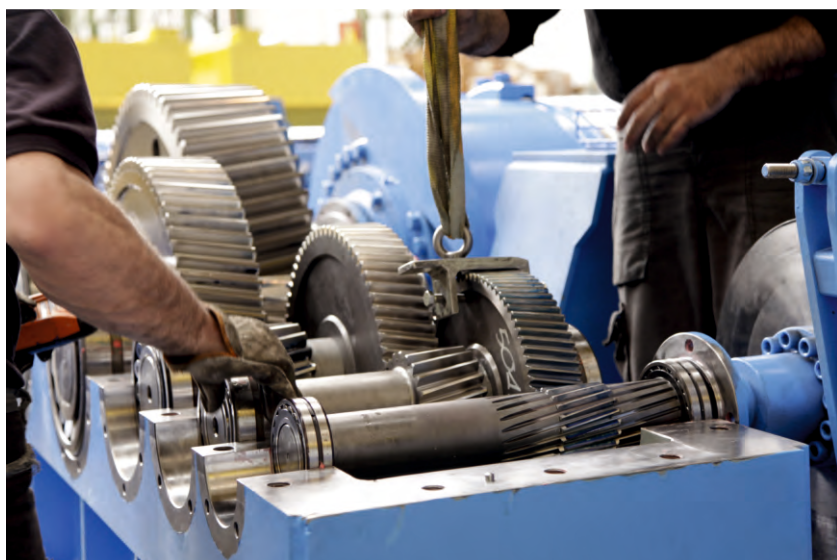

Las inexactitudes de montaje, así como la deformación de las estructuras y desgaste de las partes en funcionamiento, originan enormes fuerzas adicionales, sobre todo en el eje de salida del reductor, que debido a las fuerzas alternativas de flexión producen rotura por fatiga y averías en los rodamientos y ruedas dentadas.

En el montaje indicado en las figuras, adjunta el acoplamiento de barriletes, que se instala entre el reductor y el tambor de cable, ejerce la función de articulación haciendo la unión estáticamente determinada y evitando así la presentación de elevados momentos flectores.

**1E - Polipasto GHA12, GHB11, GHD13**

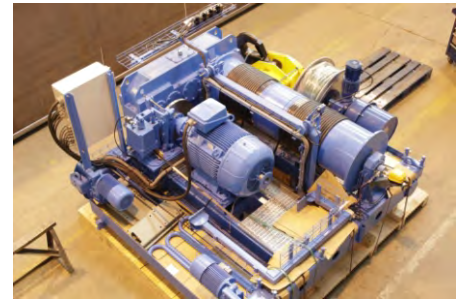
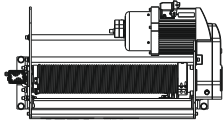

**2E - Polipasto GHE, GHF, GHG**

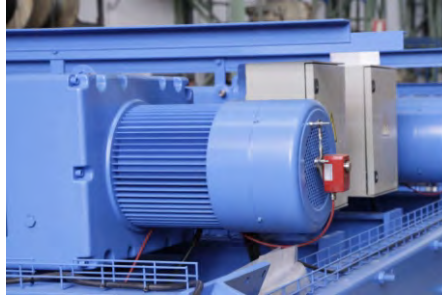
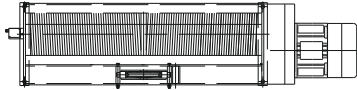

**3E - Carro abierto sencillo**

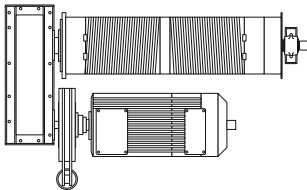

**4E - Carro abierto con doble tambor**

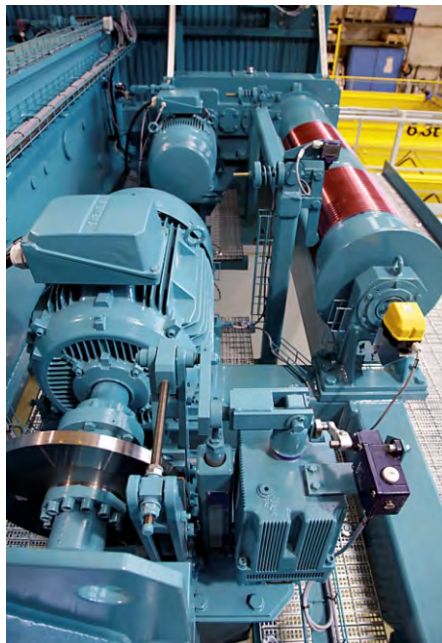
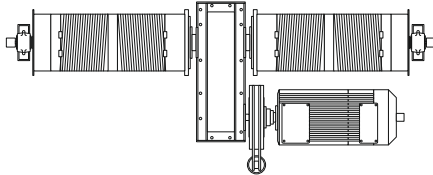

**5E - Carro abierto giratorio doble tambor**

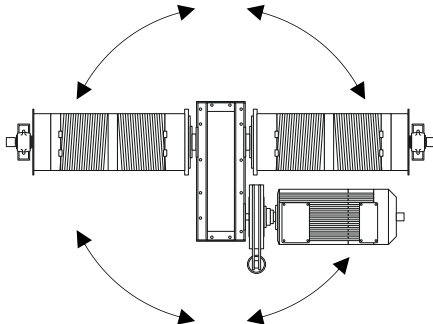

**6E - Carro abierto reductor planetario doble tambor freno de seguridad tambor**

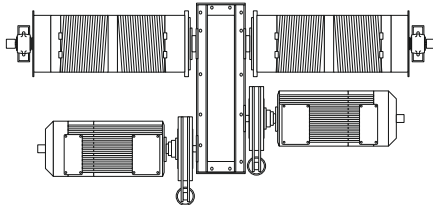

**7E - Seguridad redundante, reducciones planetarias doble tambor freno de seguridad tambor**

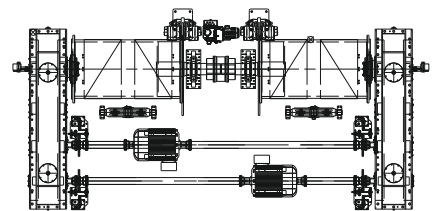

# Cinemáticas de traslación

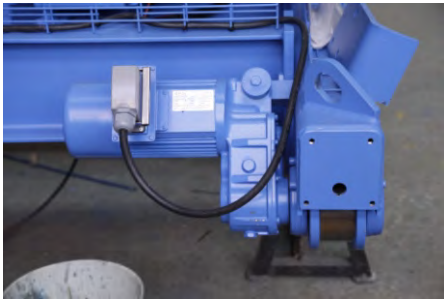

1T - Carro /

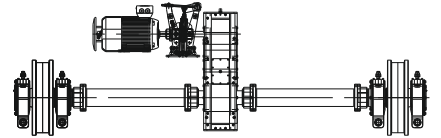

2T - Carro y puente /

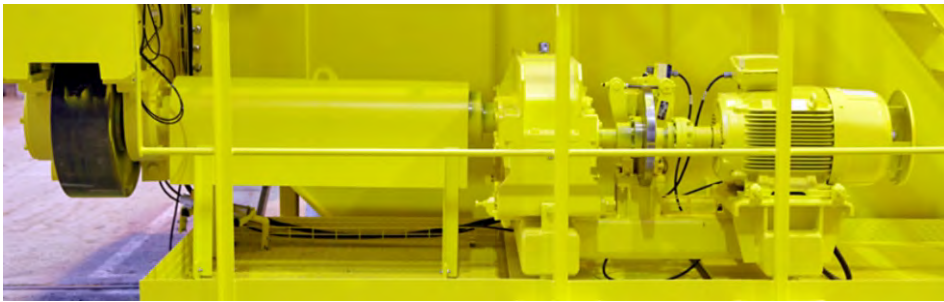
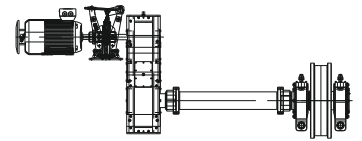

3T - Carro y puente /

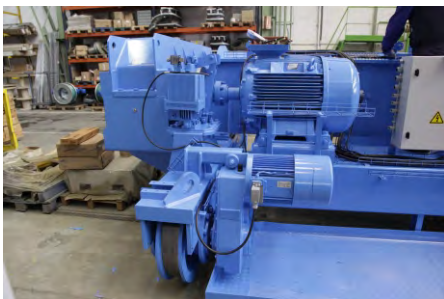
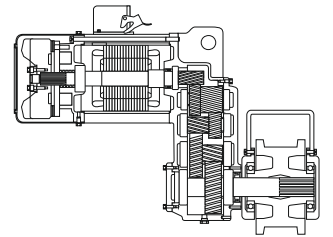

4T - Rodillos horizontales /

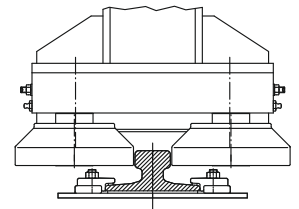

5T - Giro /

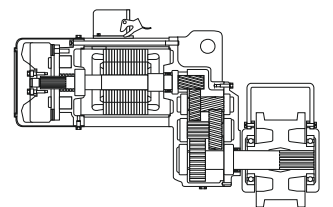

De acuerdo a la clasificación FEM, dos criterios marcan la elección del Grupo de Trabajo:

- El espectro de cargas (k)
- El tiempo medio de utilización diario (Tm)

## Clase de servicio

Método aproximado

### LIGERO - L1

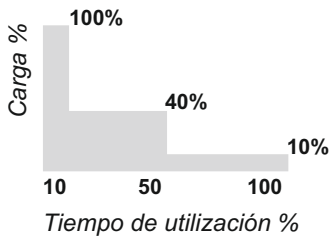

Ocasionalmente a plena carga.  
Normalmente cargas reducidas.

### MEDIO - L2

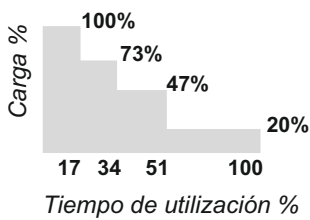

Ocasionalmente a plena carga.  
Normalmente cargas medias.

### DURO - L3

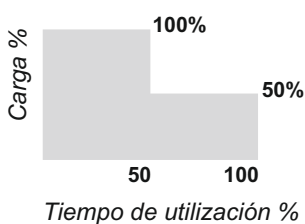

Usualmente plena carga.  
Usualmente media carga.

### MUY DURO - L4

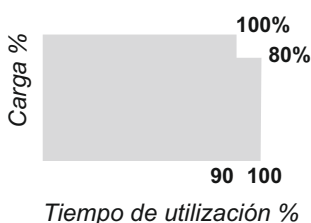

Casi siempre a plena carga.

Espectro de carga	k	Tm			
L1	Ligero	$k < 0,5$	4-8	8-16	>16
L2	Medio	$0,5 < k < 0,63$	2-4	4-8	8-16 >16
L3	Duro	$0,63 < k < 0,8$	1-2	2-4	4-8 8-16
L4	Muy duro	$0,8 < k < 1$	0,5-1	1-2	2-4 4-8
		FEM	2m	3m	4m 5m
		Grupo de mecanismos	ISO	M5	M6 M7 M8
		CMAA	C	D	E F
		GOST	3M	4M	5M 6M

Capacidad de carga	10 t	C
Altura de elevación media	6 m	Lh
Vel. Elevación	5 m/min	V
Nº ciclos/hora	12	Ch
Horas trabajo/día	8 horas	Hd
Estado sollicitación	Medio	

$$T_m = \frac{2 \times L_h \times C_h \times H_d}{60 \times V}$$

$$T_m = \frac{2 \times 6 \times 12 \times 8}{60 \times 5} = 2,56 [\text{horas}]$$

Para un espectro de carga "medio" y un tiempo medio de utilización diaria de 2,56 horas la tabla nos marca un grupo **M5**

El espectro de cargas "k" puede ser determinado de manera exacta como sigue

$$k = \sqrt[3]{\left(\frac{C_1}{C}\right)^3 \cdot \left(\frac{T_1}{T_m}\right) \dots \left(\frac{C_n}{C}\right)^3 \cdot \left(\frac{T_n}{T_m}\right)}$$

Donde (por cada ciclo)

C<sub>i</sub> Carga parcial

T<sub>i</sub> Tiempo de utilización bajo carga parcial

## Tabla de selección

Tablas de selección de grupo de mecanismo en función de la capacidad

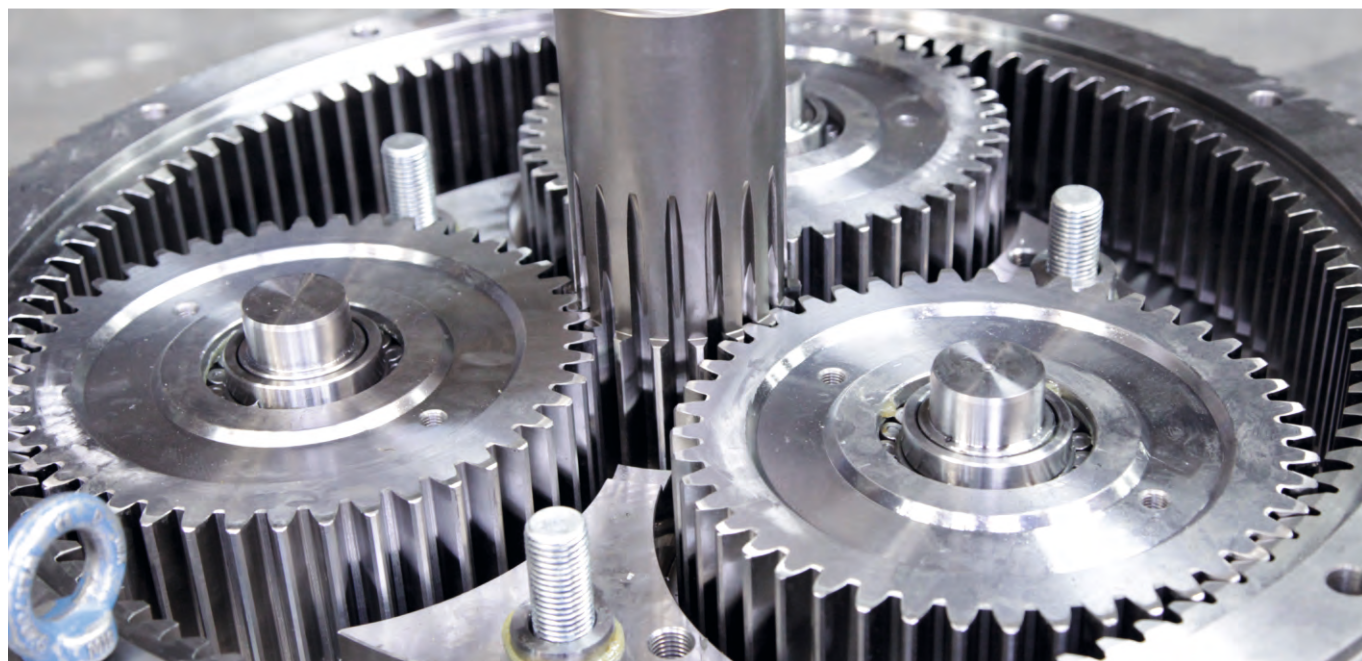

RAMALES	GHF			GHG			GHI			GHJ				GHK			
	4/2	8/2	12/2	4/2	8/2	12/2	4/2	8/2	12/2	4/2	8/2	12/2	16/2	4/2	8/2	12/2	16/2
6,3	M8																
8	M8																
10	M8																
12,5	M7	M8		M8													
16	M6	M8		M8													
20	M5	M8		M7			M8										
25		M7	M8	M6	M8		M8										
32		M6	M8	M5	M8		M7			M8							
40		M5	M7	M4	M7	M8	M6	M8		M8							
50			M6		M6	M8	M5	M8		M7				M8			
63			M5		M5	M7		M7	M8	M6	M8			M7			
80					M4	M6		M6	M8	M5	M8			M6			
100						M5		M5	M7		M7	M8		M5	M8		
125									M6		M6	M8		M4	M7		
160									M5		M5	M7	M8		M6	M8	
200												M6	M7		M5	M7	M8
250												M5	M6		M4	M6	M7
320													M5			M5	M6
400																M4	M5

Propuesta de codificación:

**025M8I042B3R08**  
25 tn de capacidad  
M8 grupo FEM

Tipo de reductora  
42 4/2 ramales del cable  
B motor brida (motor brida=B motor patas=P)

3R nº de trenes de reductora  
8 velocidad m/min

Tablas de selección para carros abiertos con ramales a 4/2.

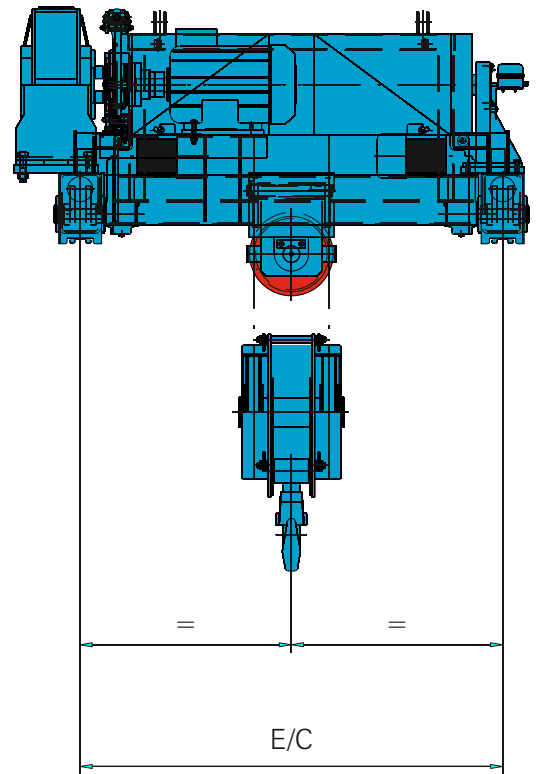
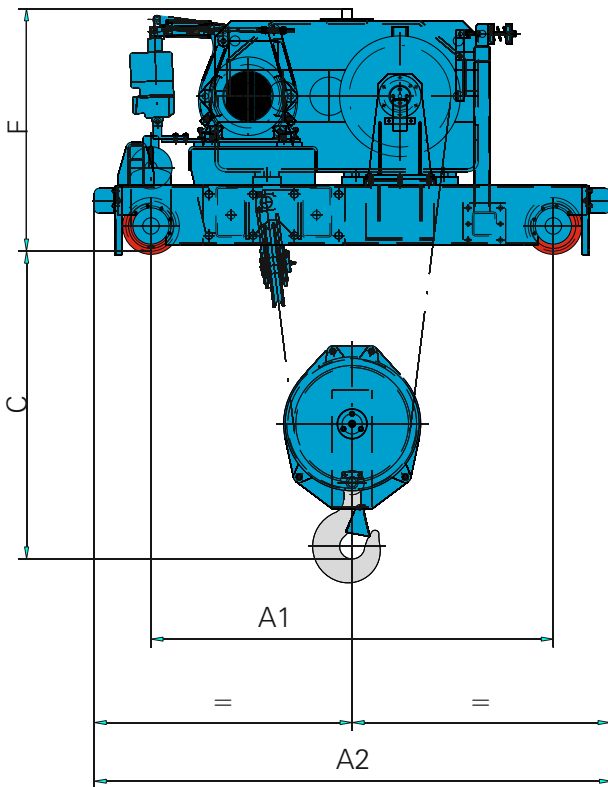

Modelo	Capacidad	Clasificación		Alturas			Velocidades					Dimensiones				E/c			Pesos		
	Ramales	t	FEM	ISO	H1	H2	H3	V1	V2	V3	V4	V5	F	C	A1	A2	H1	H2	H3	H1	H2
GHF	6,3	5 m	M8	10	15	20	6	8	12	16	20	1075	1005	1900	2465	1500	1800	2000	2600	2700	3000
	8	5 m	M8																		
	10	5 m	M8																		
	12,5	4 m	M7																		
	16	3 m	M6																		
20	2 m	M5																			
GHG	12,5	5 m	M8	10	15	20	6	8	12	16	20	1220	1270	1900	2465	1800	2000	2240	4700	4800	5100
	16	5 m	M8																		
	20	4 m	M7																		
	25	3 m	M6																		
	32	2 m	M5																		
40	1 Am	M4	1355	1085	2525																
GHI	20	5 m	M8	10	15	20	6	8	12	16	20	1450	1630	2200	2825	2000	2240	2600	11200	11600	12500
	25	5 m	M8																		
	32	4 m	M7																		
	40	3 m	M6																		
	50	2 m	M5																		
GHJ	32	5 m	M8	10	15	20	6	8	12	16	20	1625	1745	2400	3205	2000	2240	2500	15900	16100	17200
	40	5 m	M8																		
	50	4 m	M7																		
	63	3 m	M6																		
	80	2 m	M5																		
GHK	50	5m	M8	10	15	20	6	8	12	16	20	2150	2055	3500	4532	2550	2800	3050	22000	24000	26000
	63	4m	M7																		
	80	3m	M6																		
	100	2m	M5																		
	125	1Am	M4																		



# Tabla de selección

Tablas de selección para carros abiertos con ramales a 8/2.

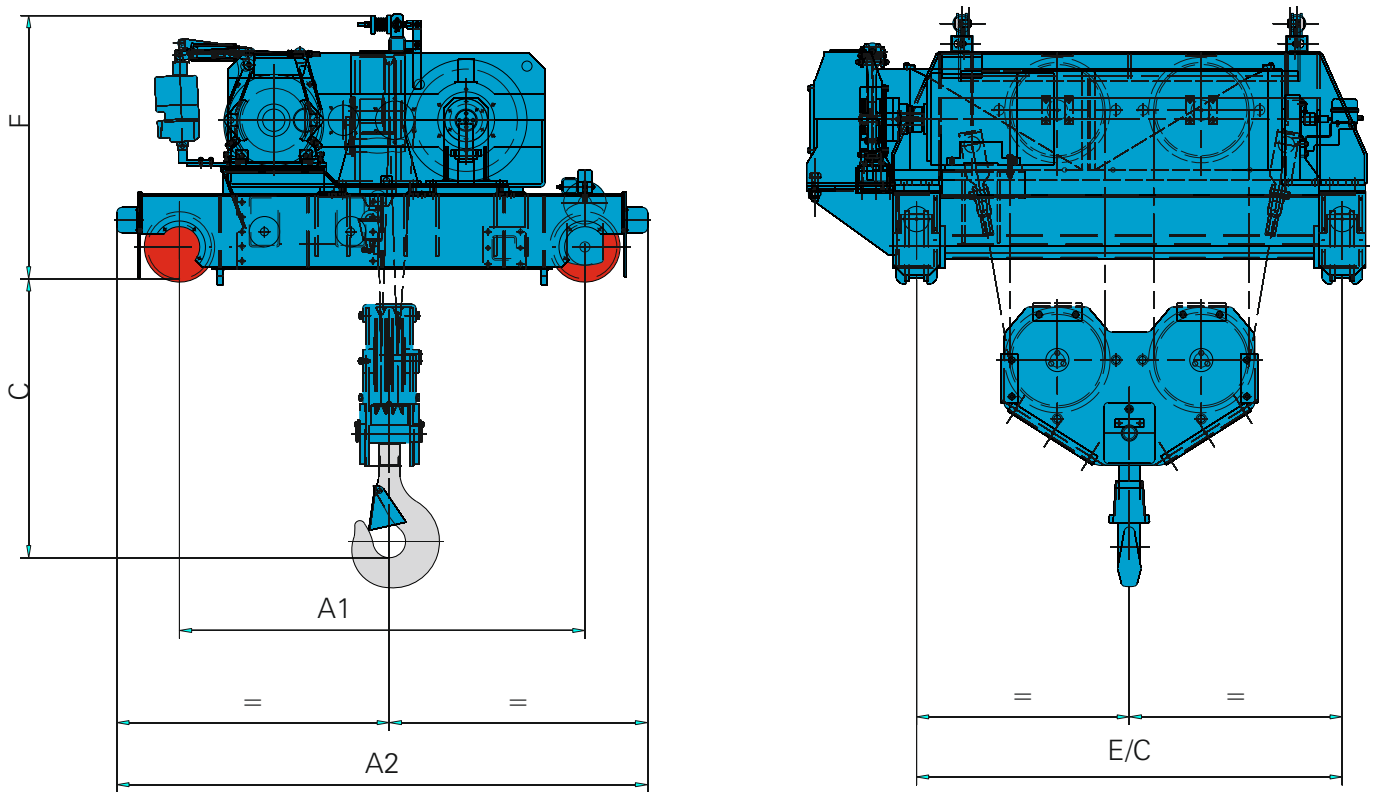

Modelo	Capacidad	Clasificación		Alturas			Velocidades					Dimensiones				E/c			Pesos		
		Ramales	t	FEM	ISO	H1	H2	H3	V1	V2	V3	V4	V5	F	C	A1	A2	H1	H2	H3	H1
GHF	12,5	5 m	M8	10	15	20	3	4	6	8	10	1165	1065	2000	2565	1800	2400	3000	3400	3700	4300
	16	5 m	M8																		
	20	5 m	M8																		
	25	4 m	M7																		
	32	3 m	M6																		
40	2 m	M5																			
GHG	25	5 m	M8	10	15	20	3	4	6	8	1355	1255	2000	2625	2000	2500	3000	5900	6200	6500	
	32	5 m	M8																		
	40	4 m	M7																		
	50	3 m	M6																		
	63	2 m	M5																		
80	1 Am	M4																			
GHI	40	5 m	M8	10	15	20	3	4	6	8	1545	1555	2400	3205	2240	2500	3150	13400	14000	14600	
	50	5 m	M8																		
	63	4 m	M7																		
	80	3 m	M6																		
	100	2 m	M5																		
GHJ	63	5 m	M8	10	15	20	3	4	6	1680	2150	2600	3600	2240	2800	3500	18700	19800	20800		
	80	5 m	M8																		
	100	4 m	M7																		
	125	3 m	M6																		
	160	2 m	M5																		
GHK	100	5m	M8	10	15	20	3	4	6	2250	1860	3500	4532	2800	3300	3800	24000	26000	28000		
	125	4m	M7																		
	160	3m	M6																		
	200	2m	M5																		
	250	1Am	M4																		

Tablas de selección para carros abiertos con ramales a 12/2 y 16/2.

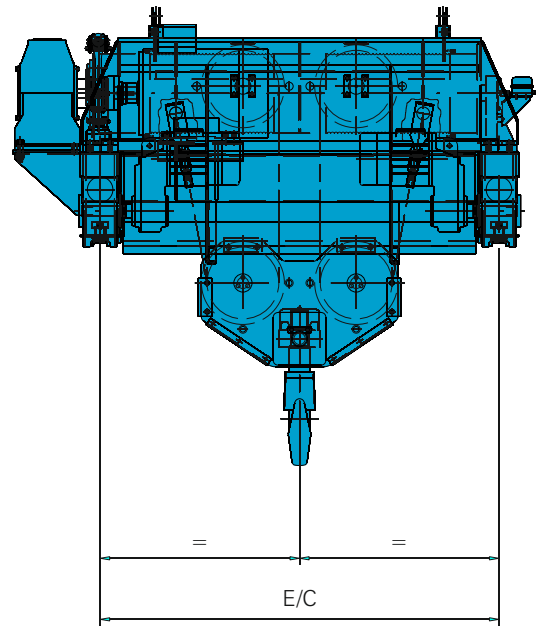
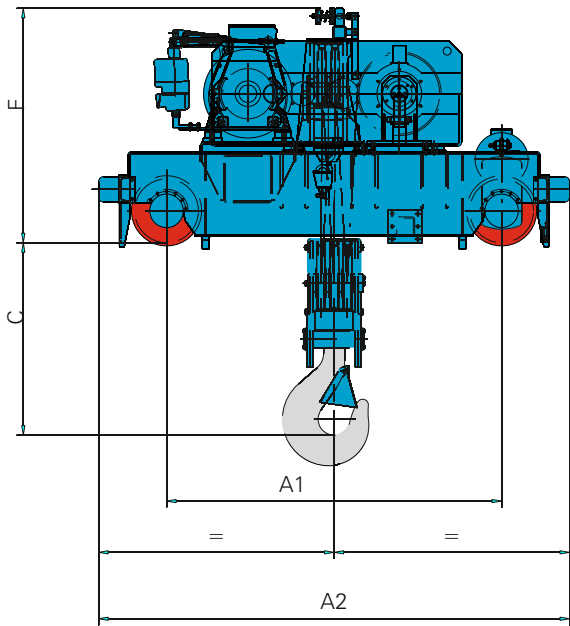

Modelo	Capacidad	Clasificación		Alturas			Velocidades					Dimensiones				E/c			Pesos		
		Ramales	t	FEM	ISO	H1	H2	H3	V1	V2	V3	V4	V5	F	C	A1	A2	H1	H2	H3	H1
GHF	25	5 m	M8	10	15	20	2	2,7	4	5,4	8	1350	1100	2000	2625	2500	3150	4000	4100	5500	5900
	32	5 m	M8																		
12/2	40	4 m	M7	10	15	20	2	2,7	4	5,4	8	1300	1060	2000	2625	2500	3150	4000	4100	5500	5900
	50	3 m	M6																		
12/2	63	2 m	M5	10	15	20	2	2,7	4	5,4	8	1450	1290	2000	2805	2500	3150	4000	7700	9000	10500
	63	2 m	M5																		
12/2	80	3 m	M6	10	15	20	2	2,7	4	5,4	8	1545	1875	2400	3205	2600	3500	4200	14900	16500	17300
	100	2 m	M5																		
12/2	100	5 m	M8	10	15	20	1	2	2,5	4	8	1745	2375	2600	3740	2800	3500	4200	21600	23800	25000
	125	3 m	M6																		
12/2	160	2 m	M5	10	15	20	1	2	2,5	4	8	2350	1885	3500	4532	3300	4050	4800	26000	29000	31000
	160	2 m	M5																		
12/2	200	4 m	M7	10	15	20	1	2	2,5	4	8	2350	1785	3500	4532	3300	4050	4800	26000	29000	31000
	250	3 m	M6																		
12/2	320	2 m	M5	10	15	20	1	2	2,5	4	8	2350	1685	3500	4532	3300	4050	4800	26000	29000	31000
	400	1Am	M4																		

Modelo	Capacidad	Clasificación		Alturas			Velocidades					Dimensiones				E/c			Pesos		
		Ramales	t	FEM	ISO	H1	H2	H3	V1	V2	V3	V4	V5	F	C	A1	A2	H1	H2	H3	H1
GHJ	160	5m	M8	10	15	20	1,5	2	2,5	3	8	2450	2270	3500	4532	3300	4050	4800	26000	29000	31000
	200	4m	M8																		
16/2	250	3m	M7	10	15	20	1,5	2	2,5	3	8	2450	2170	3500	4532	3350	4100	4850	26000	29000	31000
	320	2m	M6																		
16/2	200	5m	M8	10	15	20	1,5	2	2,5	3	8	2450	2270	3500	4532	3300	4050	4800	26000	29000	31000
	250	4m	M8																		
16/2	320	3m	M7	10	15	20	1,5	2	2,5	3	8	2450	2170	3500	4532	3300	4050	4800	26000	29000	31000
	400	2m	M6																		

## Carro Abierto Giratorio

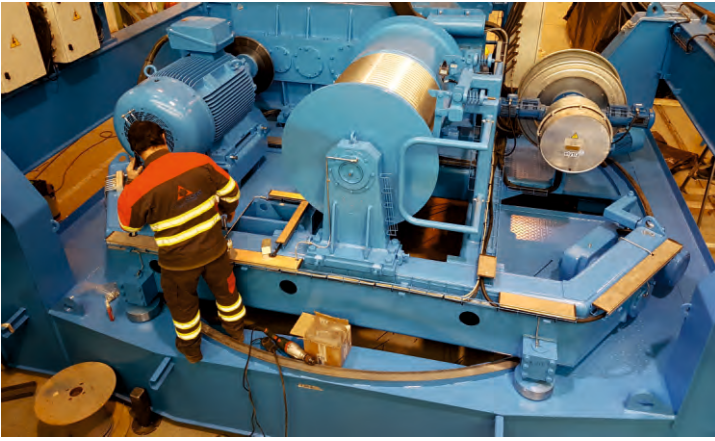

Opción interesante para el manejo de traviesas, ya sean para manipular palanquilla, productos largos, bobinas de papel o cazo de chatarra o metal líquido.

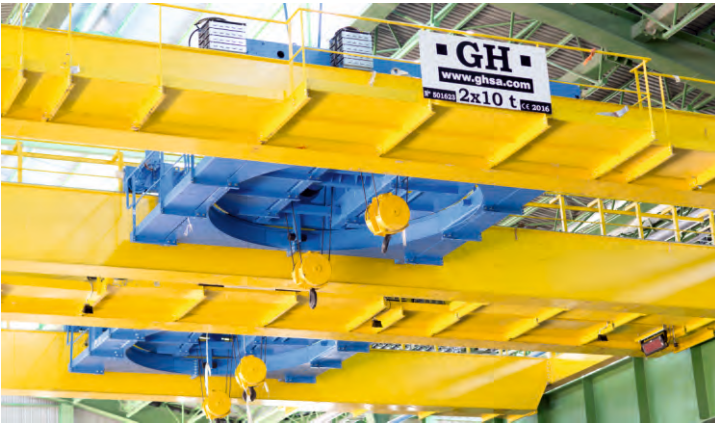

Presencia en  
**+70 PAISES**  
EN 5 CONTINENTES

**+ 125.000**  
grúas instaladas

**+ 992** 

EN EL  
**TOP 5** FABRICANTES  
DE GRÚAS  
DEL MUNDO

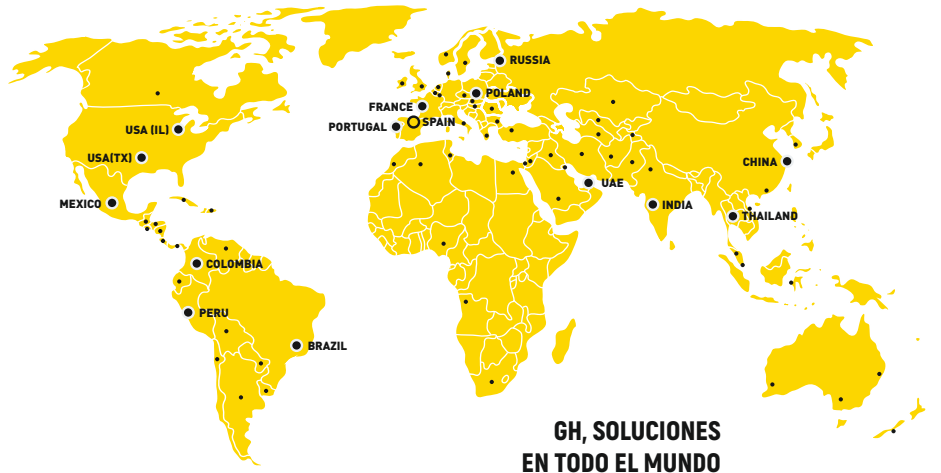

**GH, SOLUCIONES  
EN TODO EL MUNDO**

**-GH-**

**GH, España sede central**

**www.ghcranes.com**



**Beasain**

OFICINAS CENTRALES  
T: +34 943 805 660  
ghcranes@ghcranes.com



**Olaberria**

GH GLOBAL SERVICE  
T: +34 902 205 100  
globalservice@ghcranes.com



**Alsasua**

MECANIZADO  
T: +34 948 467 625



**Bakaiku**

FABRICACIÓN GRÚAS  
T: +34 948 562 611



**Jaén**

REPUESTOS  
T: +34 902 205 100

**GH, filiales en el mundo**



**Brasil**

Cabreúva

GH DO BRASIL IND. E COM. LTDA.  
T: +52 1144090066  
vendas@ghcranes.com.br



**China**

Shanghai

GH (SHANGHAI)  
LIFTING EQUIPMENT CO., LTD.  
T: +86 21 5988 7676  
ghcranes@ghcranes.com.cn



**Colombia**

Bogotá

GH COLOMBIA SAS  
T: +57 1 750 4427  
ventasghcolombia@ghcranes.com



**Francia**

Couëron

GH FRANCE SA  
T: +33(0) 240 861 212  
ghfrance@ghcranes.com



**India**

Pune

GH CRANES INDIA PVT. LTD.  
T: +91 89561 35444  
ghindia@ghcranes.com



**México**

Querretaro

GRÚAS GH MEXICO SA DE CV  
T: +52 44 22 77 55 03  
+52 44 22 77 50 74  
ghmexico@ghsa.com.mx



**Perú**

Lima

GH PERÚ S.A.C.  
T: +51 987816231  
gferradas@ghcranes.com



**Polonia**

Klobuck

GH CRANES SP. Z O.O.  
T: +48 34 359 73 17  
office@ghsa.pl



**Portugal**

Mamede do Coronado

GH PORTUGAL  
T: +351 229 821 688  
geral@ghcranes.com

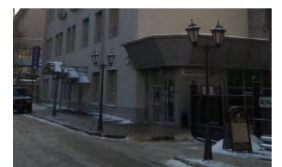

**Rusia**

Moscú

GH RUSSIA  
T: +7 (495) 745 69 26  
ghrussia@ghcranes.com



**Tailandia**

Chonburi

LGH CRANES CO., LTD.  
T: +66 (0)-2327 9399  
ghthailand@ghcranes.com



**UAE**

Dubai

GH Cranes Arabia FZCO  
T: +971 4 8810773  
gharabia@ghcranes.com



**EEUU**

Illinois

GH Cranes & Components USA- IL  
T: (815) 277 5328  
ghcranesusa@ghcranes.com



**EEUU**

Texas

GH Cranes & Components USA- TX  
T: (972) 563 8333  
ghcranesusa@ghcranes.com

**Lifting  
your  
world.**